

1.8V/2.5V, 250MHz, Low Skew 1:6 Crystal to LVC MOS Clock Buffer
Features

- Six low skew outputs: < 80ps
- Crystal oscillator input: 10MHz to 40MHz
- Switching frequency up to 250 MHz
- Fast output rise/fall time: < 800ps
- Synchronous output enables
- Industrial Temperature range: -40°C to +85°C
- 1.8V and 2.5V operation
- Packaging (Pb-free & Green available):
 - 16-pin 173-mil wide TSSOP (L)

Description

Pericom Semiconductor's PI6C10806 is a low skew six output crystal oscillator driver. Crystal oscillator input range is from 10MHz to 40MHz. If XTAL_IN is driven with a signal source, then the input frequency can be as high as 250MHz. PI6C10806, the outputs are configured into 2 groups: a five output and a single output; each with independent output enable.

PI6C10806 has a wide range of operating voltages: 1.8V and 2.5V. This feature paired with the low output-to-output and part-to-part skew makes the device ideal for low voltage, low power, high frequency single ended applications; such as networking

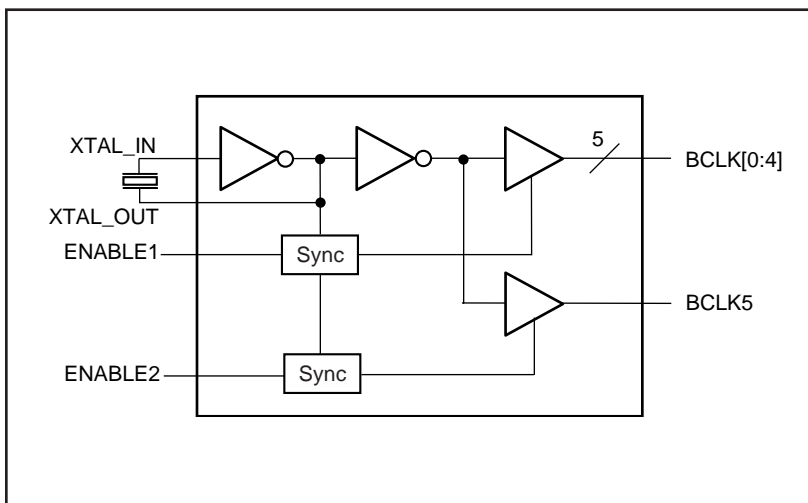
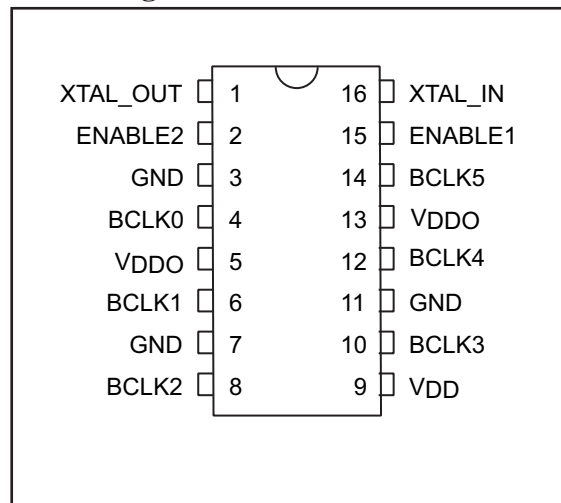
Block Diagram

Pin Configuration

Pin Description

Pin Name	Description
ENABLE1, ENABLE2	Active High Output Enable Inputs
XTAL_IN	Crystal interface
XTAL_OUT	Crystal interface
BCLK[0:5]	Clock Outputs
GND	Ground
V _{DD}	Core Power
V _{DDO}	Output Power

Truth Table⁽¹⁾

Inputs		Outputs	
ENABLE1	ENABLE2	BCLK[0:4]	BCLK5
L	L	L	L
L	H	L	Switching
H	L	Switching	L
H	H	Switching	Switching

Note:

1. H = High Voltage Level, L = Low Voltage Level

2.5V Absolute Maximum Ratings (Above which the useful life may be impaired. For user guidelines only, not tested.)

Storage Temperature.....	-65°C to +150°C
V _{DD} , V _D DO Voltage.....	-0.5V to +3.6V
Output Voltage (max. 3.6V).....	-0.5V to V _{DD} +0.5V
Input Voltage (max 3.6V).....	-0.5V to V _{DD} +0.5V

Note:
 Stresses greater than those listed under MAXIMUM RATINGS may cause permanent damage to the device. This is a stress rating only and functional operation of the device at these or any other conditions above those indicated in the operational sections of this specification is not implied. Exposure to absolute maximum rating conditions for extended periods may affect reliability.

2.5V I/O DC Characteristics (Over Operating Range: V_{DD} = 2.5V ± 5%, T_A = -40° to 85°C)

Parameters	Description	Test Conditions ⁽¹⁾	Min.	Typ. ⁽²⁾	Max.	Units
V _D DO	I/O Supply Voltage		2.375	2.5	2.625	
V _I H	Input HIGH Voltage	Logic HIGH level	1.7		V _{DD} +0.3	V
V _I L	Input LOW Voltage	Logic LOW level	-0.3		0.7	
V _O H	Output High Voltage	V _D DO = Min., V _I N = V _I H or V _I L	I _O H = -1mA	2		V
			I _O H = -8mA	2		
V _O L	Output LOW Voltage	V _D DO = Min., V _I N = V _I H or V _I L	I _O L = 1mA		0.4	V
			I _O L = 8mA		0.4	

Notes:

- For Max. or Min. conditions, use appropriate operating range values.
- Typical values are at V_{CC} = 2.5V, +25°C ambient and maximum loading.

2.5V I/O AC Characteristics (Over Operating Range: V_{DD}/V_DDO = 2.5V ± 5%, T_A = -40° to 85°C)

Parameters	Description	Test Conditions ⁽¹⁾	Min.	Typ	Max.	Units
f _O UT	Output Frequency	Using Crystal	10		40	MHz
		External Clock ⁽²⁾	0		250	
t _D C	Output Duty Cycle	@ V _D DO/2	47		53	%
t _R /t _F	CLKn Rise/Fall Time	20% to 80%	150		800	ps
t _S K(O) ⁽³⁾	Output to Output Skew between any two outputs of the same device @ same transition	@V _D DO/2			60	ps
t _D IS,t _E N ⁽⁴⁾	Output Enable/Disable	@V _D DO/2			4	cycles

Notes:

- Unless noted otherwise, all parameters are tested with xtal @ f ≤ Fxtal_max,; outputs are terminated @ 50Ω to V_DDO/2, see waveforms.
- External clock source is driving XTAL_IN input
- Identical conditions: loading, transitions, supply voltage, temperature, package type and speed grade.
- These parameters are guaranteed, but not tested.
 Min & Max delay is 4 cycles.

1.8V Absolute Maximum Ratings (Above which the useful life may be impaired. For user guidelines only, not tested.)

Storage Temperature.....	-65°C to +150°C
V _{DDO} , V _{DD} Voltage.....	-0.5V to +2.5V
Output Voltage (max 2.5V)	-0.5V to V _{DD} +0.5V
Input Voltage (max 2.5V)	-0.5V to V _{DD} +0.5V

Note:
 Stresses greater than those listed under MAXIMUM RATINGS may cause permanent damage to the device. This is a stress rating only and functional operation of the device at these or any other conditions above those indicated in the operational sections of this specification is not implied. Exposure to absolute maximum rating conditions for extended periods may affect reliability.

1.8V I/O DC Characteristics (Over Operating Range: T_A = -40° to 85°C)

Parameters	Description	Test Conditions ⁽¹⁾	Min.	Typ. ⁽²⁾	Max.	Units
V _{DD}	2.5V Core Supply		2.375	2.5	2.625	V
	1.8V Core Supply		1.6	1.8	2.0	
V _{DDO}	I/O Supply Voltage		1.6	1.8	2.0	
V _{IH}	Input HIGH Voltage	Logic HIGH level	0.65*V _{DD}		V _{DD} +0.3	
V _{IL}	Input LOW Voltage	Logic LOW level	-0.3		0.35*V _{DD}	
I _L	Input Current	V _{DD} = Max, V _{IN} = V _{DD} or GND	I pin		15	μA
V _{OH}	Output High Voltage	V _{DD} = Min., V _{IN} = V _{IH} or V _{IL}	I _{OH} = -2mA	1.2		V
			I _{OH} = -8mA	1.2		
V _{OL}	Output Low Voltage	V _{DD} = Min., V _{IN} = V _{IH} or V _{IL}	I _{OL} = 2mA		0.35	
			I _{OL} = 8mA		0.35	

- Notes:**
- For Max. or Min. conditions, use appropriate operating V_{DD} and T_A values.
 - Typical values are at V_{CC} = 1.8V, +25°C ambient and maximum loading.

1.8V I/O AC Characteristics (Over Operating Range: V_{DDO} = 1.8V ± 0.2V, T_A = -40° to 85°C)

Parameters	Description	Test Conditions ⁽¹⁾	Min.	Typ	Max.	Units
V _{DD}	2.5V Core Supply		2.375	2.5	2.625	V
	1.8V Core Supply		1.6	1.8	2.0	
f _{OUT}	Output Frequency	Using Crystal	10		40	MHz
		External Clock ⁽²⁾	0		180	
t _{DC}	Output Duty Cycle	@ V _{DDO} /2	47		53	%
t _R /t _F	CLKn Rise/Fall Time	20% to 80%	150		800	ps
t _{SK(O)} ⁽³⁾	Output to Output Skew between any two outputs of the same device @ same transition	@V _{DDO} /2			60	ps
t _{DIS} , t _{EN} ⁽⁴⁾	Output Enable/Disable	@V _{DDO} /2			4	cycles

- Notes:**
- Unless noted otherwise, all parameters are tested with xtal @ f ≤ F_{xtal_max}; outputs are terminated @ 50Ω to V_{DDO}/2, see waveforms.
 - External clock source is driving XTAL_IN input
 - Identical conditions: loading, transitions, supply voltage, temperature, package type and speed grade.
 - These parameters are guaranteed, but not tested.
 Min & Max delay is 4 cycles.

Phase Noise and Jitter

(Over Operating Range: $V_{DD} = V_{DDO} = 1.8V \pm 0.2V$, and $V_{DD} = V_{DDO} = 2.5V \pm 5\%$, $T_A = -40^\circ$ to $85^\circ C$)

Symbol	Description	Test Conditions ⁽¹⁾	Min.	Typ	Max.	Units
t_{JIT}	Random RMS Phase Jitter	25MHz @ Integration Range 100Hz ~ 1MHz		0.5		ps
PN	Phase Noise Power	Offset Range 1MHz ~ 20MHz			-125	dBc/Hz

Jitter (25MHz, 100Hz to 1MHz \approx 0.5 AS (typical))

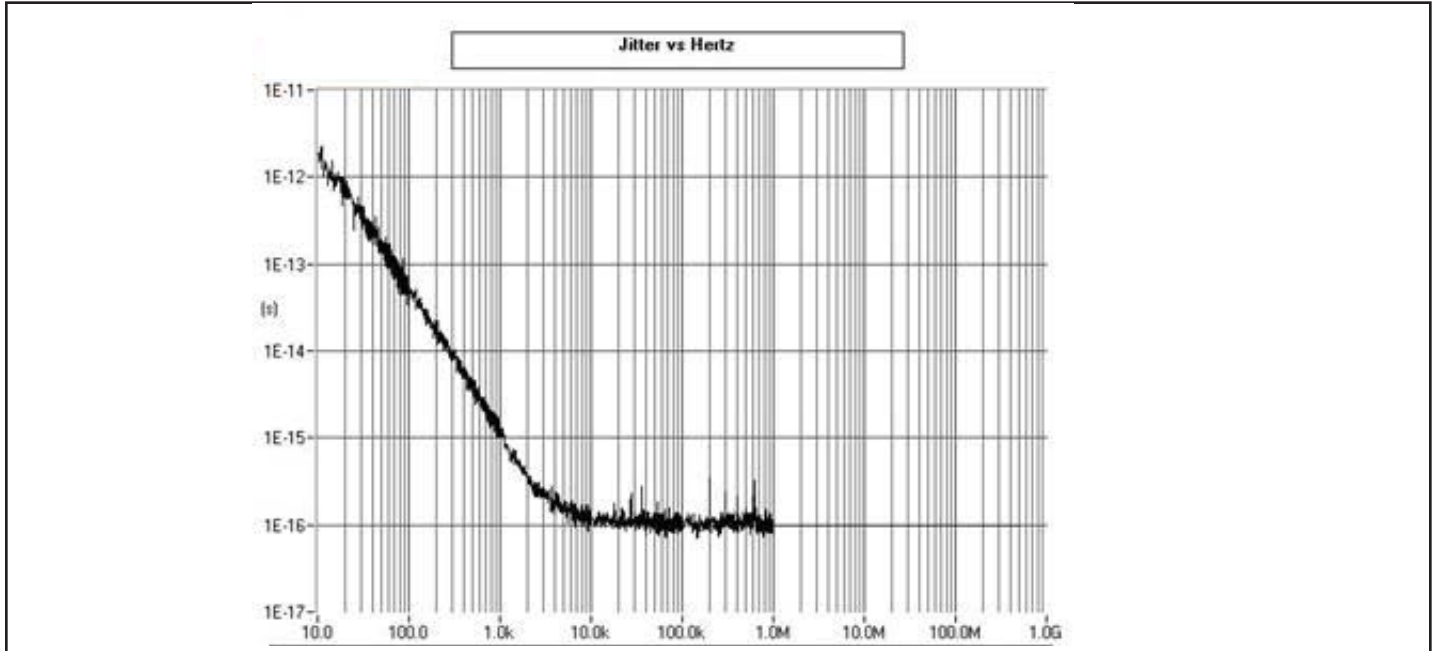

Waveforms

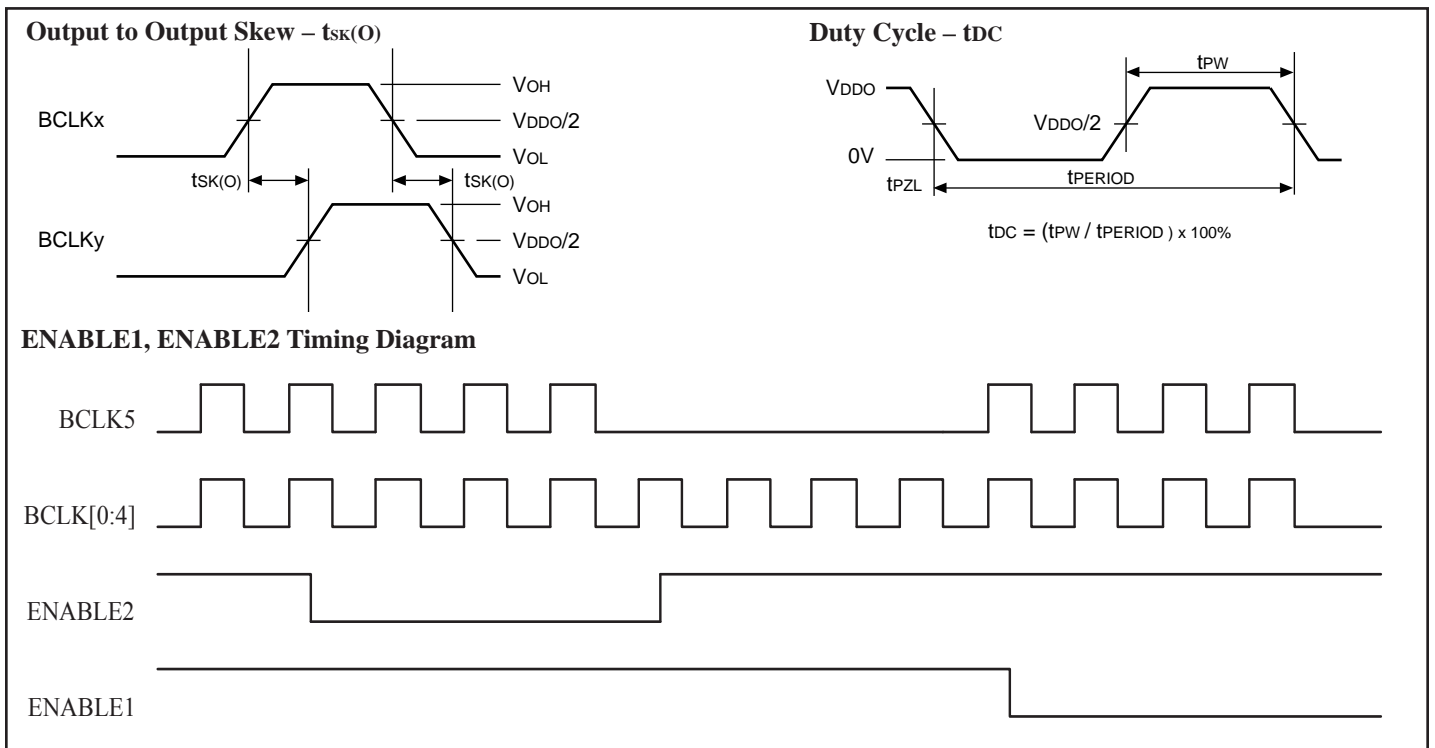

AC Test Circuit Load

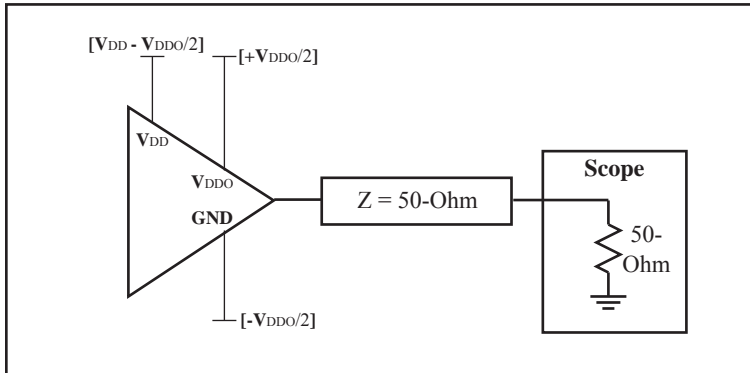

Crystal Characteristic (link to "<http://www.pericom.com/saronix>" for more detailed crystal specifications)

Parameters	Description	Min	Typ	Max.	Units
OSCMODE	Mode of Oscillation	Fundamental			
FREQ	Frequency	10	25	40	MHz
ESR ⁽¹⁾	Equivalent Series Resistance	30		200	Ohm
CLOAD	Load Capacitance	16		32	pF
CSHUNT	Shunt Capacitance			7	pF
DRIVE	Operating Drive Level			0.5	mW
	Correlation Drive Level			0.1	mW

Note: $V_{DD}/V_{DDO} = 1.8V \pm 0.2V,$
 $2.5V \pm 5\%$

Note: 1. ESR value is dependent upon frequency of oscillation

Application Notes

Crystal circuit connection

The following diagram shows PI6C10806 crystal circuit connection with a parallel crystal. For the $C_L=18\text{pF}$ crystal, it is suggested to use $C1=18\text{pF}$, $C2=18\text{pF}$. $C1$ and $C2$ can be adjusted to fine tune to the target ppm of crystal oscillator according to different board layouts. $R1=100\Omega$ is strongly suggested.

Crystal Oscillator Circuit

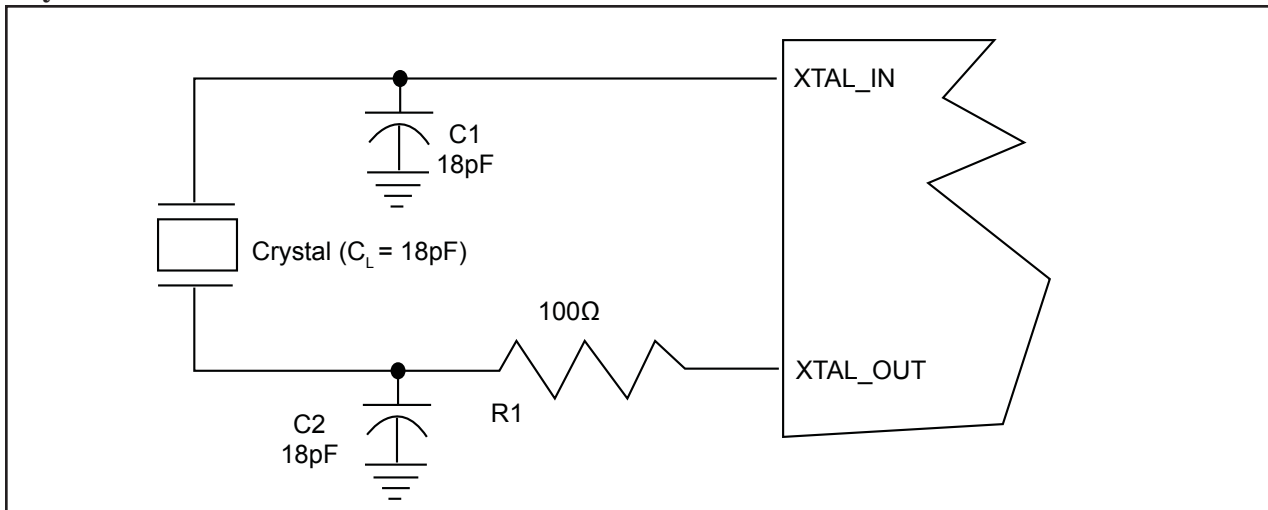

Package Mechanical - 16-lead TSSOP (L)

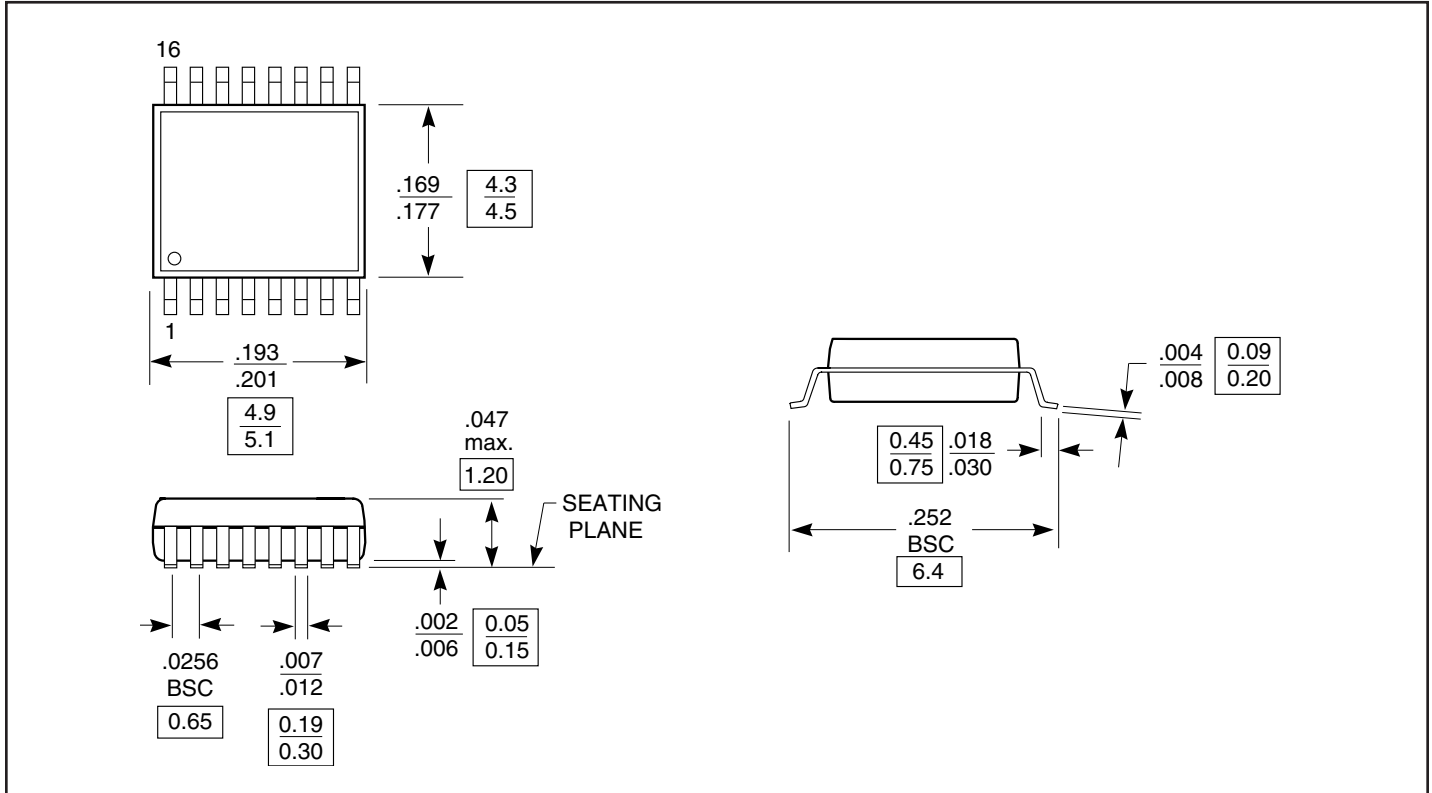

PI6C10806 Ordering Information^(1,2,3)

Ordering Code	Package Code	Package Description
PI6C10806LE	L	Pb-Free and Green 16-pin 173-mil TSSOP

Notes:

1. Thermal characteristics can be found on the company web site at www.pericom.com/packaging/
2. E = Pb-free and Green
3. X suffix = Tape/Reel

Packaging Information: HC-49

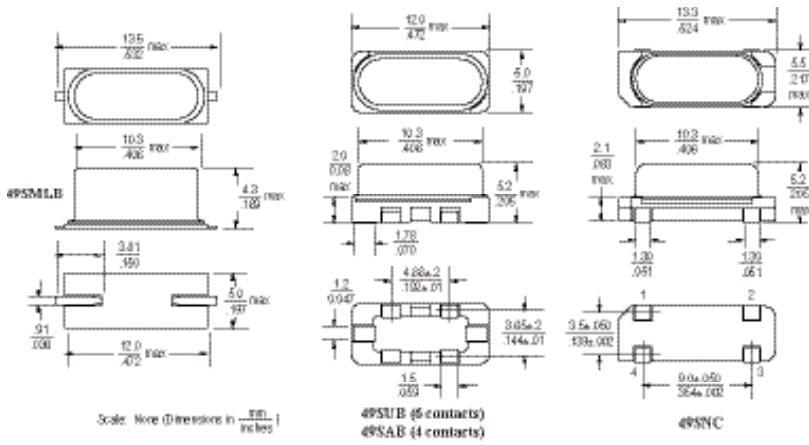

Package Marking Information

Line 1: S = SaRonix
xxx = Calib/Stability/Temp Code
YYWWX = Date Code
Line 2: Frequency (up to 7 digits, including decimal point)
BT-cut = B or
AT-cut Parallel = -(dash) or
AT-cut Series = leave Blank
xx = Load Capacitance (leave Blank if Series)

Land Pattern

Land Pattern

SxxxYYWWX
25.0000-xx

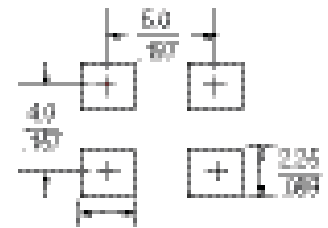

Pericom/Saronix Miniature Low Profile SMD Quartz Crystal Ordering Information

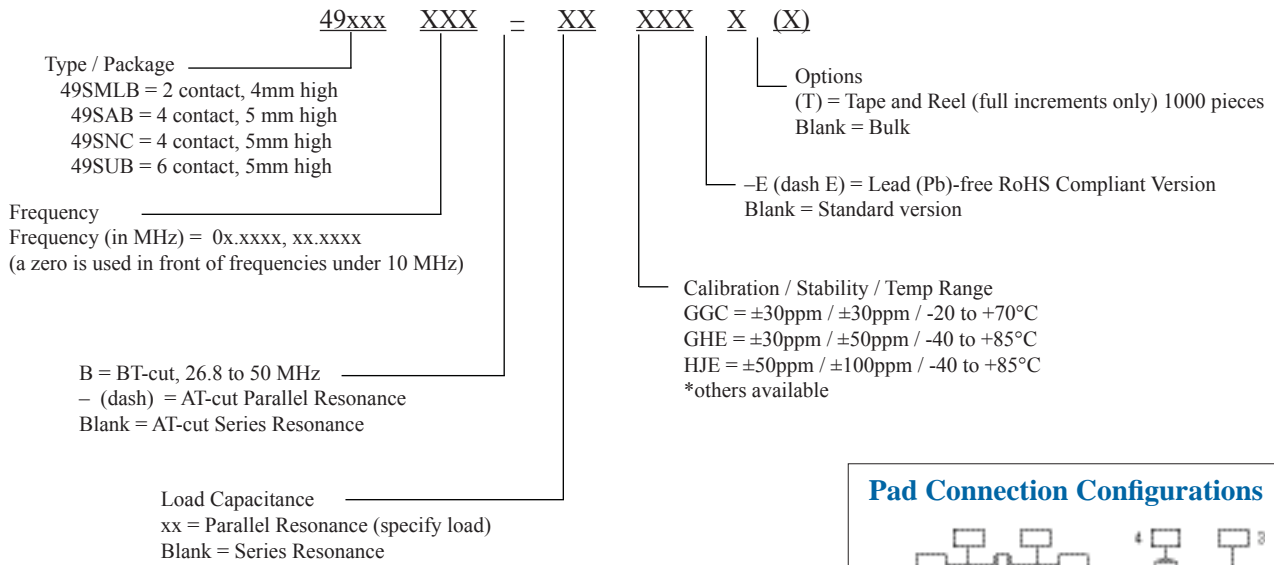

Examples:

25.0000MHz, ±30ppm calib, ±30ppm stability, -20 to +70°C (Commercial), 16pF
49SMLB25.0000-16GGC
49SMLB25.0000-16GGC-E (for lead-free)

25.0000MHz, ±30ppm calib, ±30ppm stability, -40 to +85°C (Industrial), 16pF
49SMLB25.0000-16GHE
49SMLB25.0000-16GHE-E (for lead-free)

